

SLINGERLANDS FIRE DISTRICT PUMPER/TANKER

TID NO. 13525



BODY

- Bolted Stainless Steel Body
- ROM Painted Roll Up Doors
- Rear Slide-In Through Tank Ladder and Pike Pole Storage
- Rear Slide-In Through Tank Hard Suction Storage
- Storage for 11 SCBA Bottles in Wheel Wells
- Roll-Out Storage Trays
- Rear Mounted Tow Hooks
- In-Compartment Mounted Tool Boards
- Swing-Out Toolboard

TANK

- 2500 Gallon UPF Tank
- ICI SL Plus Tank Gauge
- Syntex 2500 Gallon Portable Tank
- Zico Painted Hydraulic Porta-Tank Rack
- 4" Rear Direct Tank Fill
- 2.5" Rear Direct Tank Fill
- Rear Master Intake Rear Manual Swivel Dump Chute with Electric Valve
- Front Bumper Master Intake

ELECTRICAL

- Whelen LED Arrowstick
- Whelen Warning Lighting
- Onan 8000 Watt Hydraulic Generator
- Fire Research SPA530-Q28 Telescoping Lights
- (2) Whelen PFH2 Brow Lights
- Akron Revel Scene Lights on Body
- FRC Spectra Max Scene Lights on Cab
- Electric Cord Reel
- ILI LED Strip Compartment Lighting

CHASSIS

- Spartan Metro Star EMFD with 10" Raised Roof
- Cummins ISX12 525 HP Engine
- 4000 EVS Transmission
- Seating for 6 Firefighters
- Back-Up Camera
- In-Cab Mounted Flashlights
- In-Cab Mounted Toolboards
- Front Mounted Tow Hooks

PUMP

- Hale Qmax 1500 GPM Pump
- Fire Research Throttle Excel Pressure Governor
- Akron Apollo Monitor
- Left side: (2) 2.5" Discharges
2.5" Intake
Master Intake
- Right side: 2.5" Discharge
4" Discharge
2.5" Intake
Master Intake
- Front Bumper Hosewell with 2.5" Discharge
- 2.5" Crosslay
- (2) 1.75" Crosslays
- Booster Reel
- Rear 3" Discharge

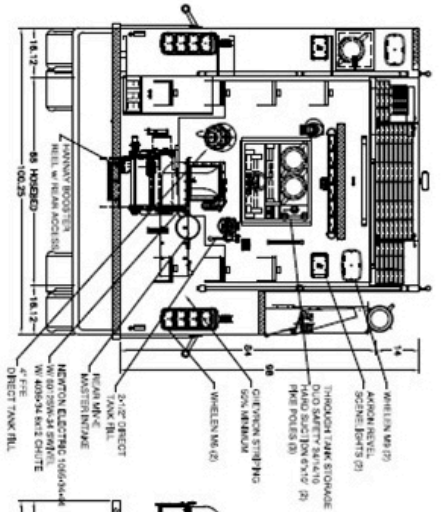

COMP.	HEIGHT	WIDTH	USABLE DEPTH		DRIVE	FT.
			UPPER	LOWER		
DAW	67.12	47.88	14	26	28	35.35
DAW x2	37.12	61.75	14	—	—	19.18
DFW	67.12	44.00	14	26	28	32.49
DFW x2	45.12	47.88	14	26	—	35.55
PAW	15.12	61.75	14	—	—	19.18
PAW x2	45.12	44.00	14	26	28	32.49
HOSSEAD	14	68	—	—	188	204
FRONT XRAY	16	7.5	—	—	73.75	31.2
MIDDLE XRAY	16	7.5	—	—	73.75	31.2
REAR XRAY	16	11	—	—	73.75	31.2

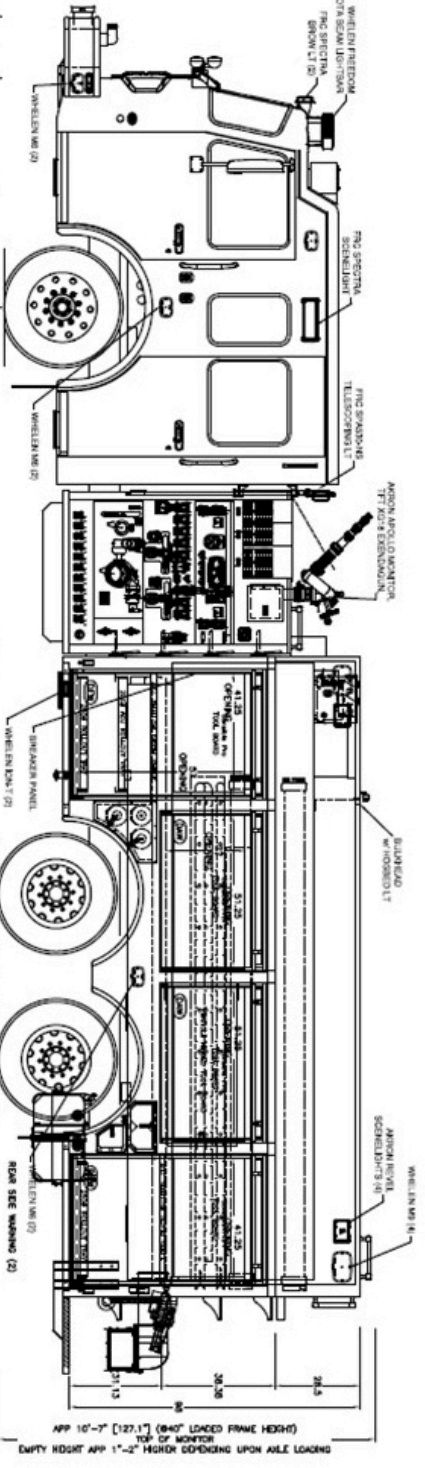
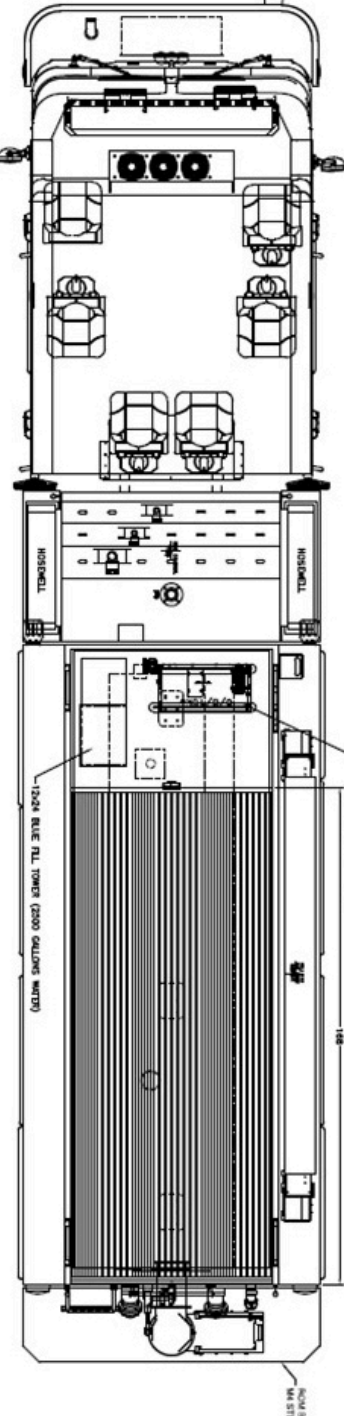
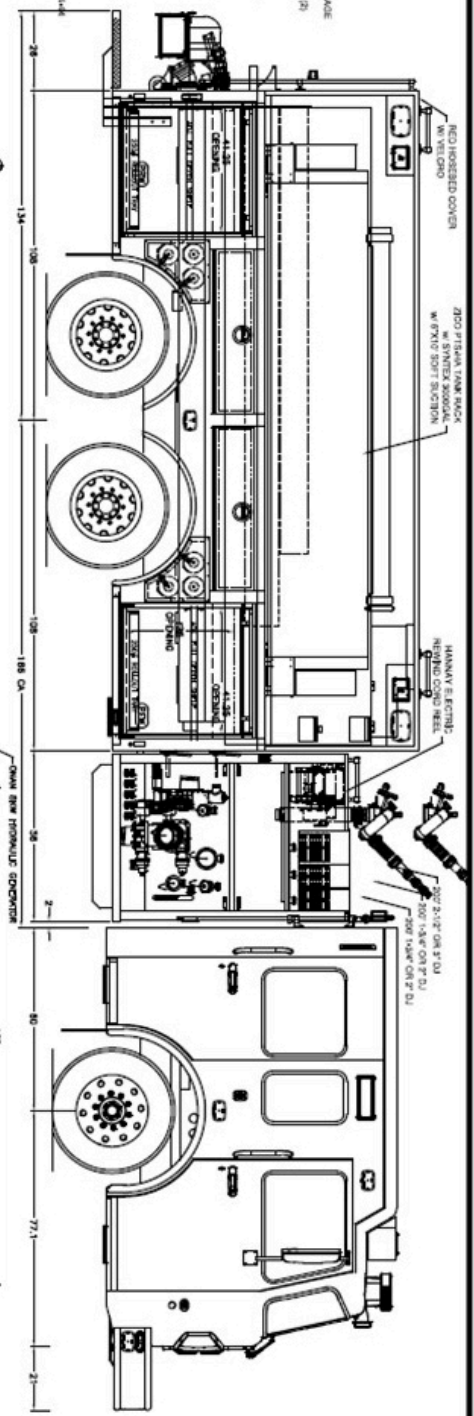
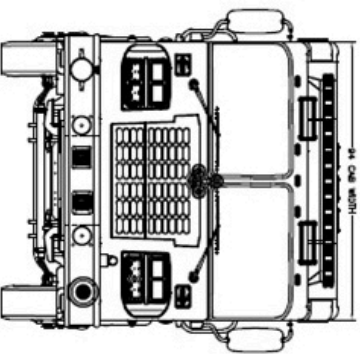

APP 10'-7" [327.1"] (840" LOADED FRAME HEIGHT)
 TOP OF MONITOR
 EMPTY HEIGHT APP 1'-2" HEIGHT GOING UPON AXLE LOADING

NOTE:
 DIMENSIONS SHOWN ARE APPROXIMATE AND ARE SUBJECT TO MINOR CHANGE AS MAY BE FOUND NECESSARY DURING CONSTRUCTION. MINOR DETAILS MAY NOT BE SHOWN. IF DISCREPANCIES EXIST BETWEEN THIS DRAWING AND THE WRITTEN SPECIFICATIONS PROVIDED BY TOWNE, THE WRITTEN SPECIFICATIONS SHALL PREVAIL.

ORIGINAL DRAWING:	12MAY21	CHASSIS:	SPARTAN METROSTAR EMFD 10' RR	SCALE:	1/66	SHEET:	A
REV. A	25OCT21	WB-CAF:	226-166-107 017	CITY:	SLINGERLANDS		
	15DEC22	BODY MNTL:	BOLTED STAINLESS STEEL	STATE:	NY		
CO 142	03FEB23	PUMP:	HALE QMAX 1500	DUR:	VRS		
AS BUILT BEB	20FEB24	TANK:	2500 UPE POLY-TANK III	CAD:	GROSSMAN		
		FOAM SYSTEM:	N/A	DATE:	12 MAY 2021		
		GENERATOR:	QWAN 8KW HYDRAULIC	FILE:	SLINGERLANDS21		

SLINGERLANDS
 CUSTOM PUMPER

BREDA, IA 51436
 800-648-3358
 WWW.TOWNE.COM

Towne
 Don't take the call.